

GRAUTE

EXIBIR X
RECORTE PARA PRATO DIANTEIRO
ESCALA 1:10

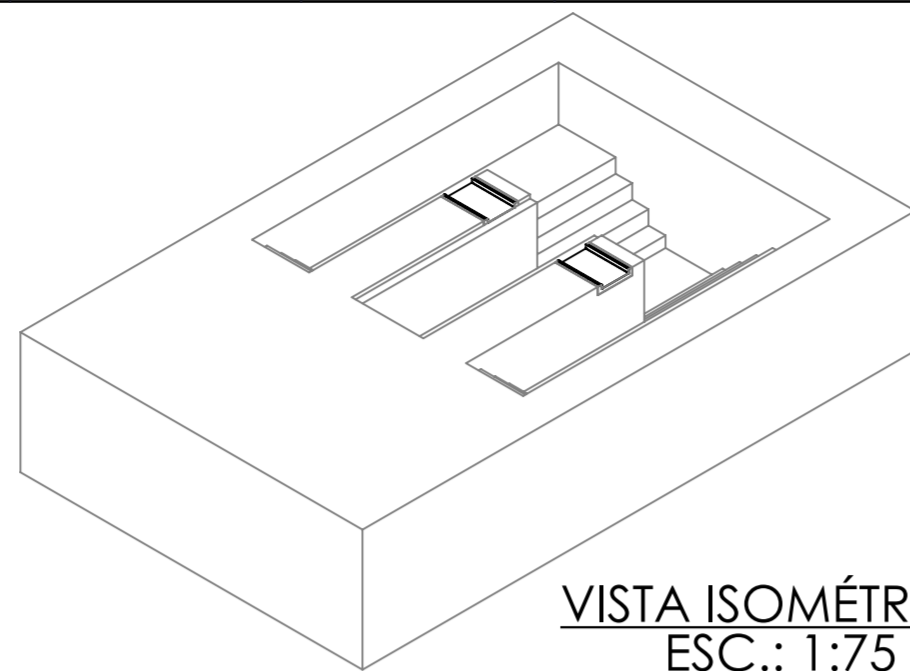

VISTA ISOMÉTRICA
ESC.: 1:75

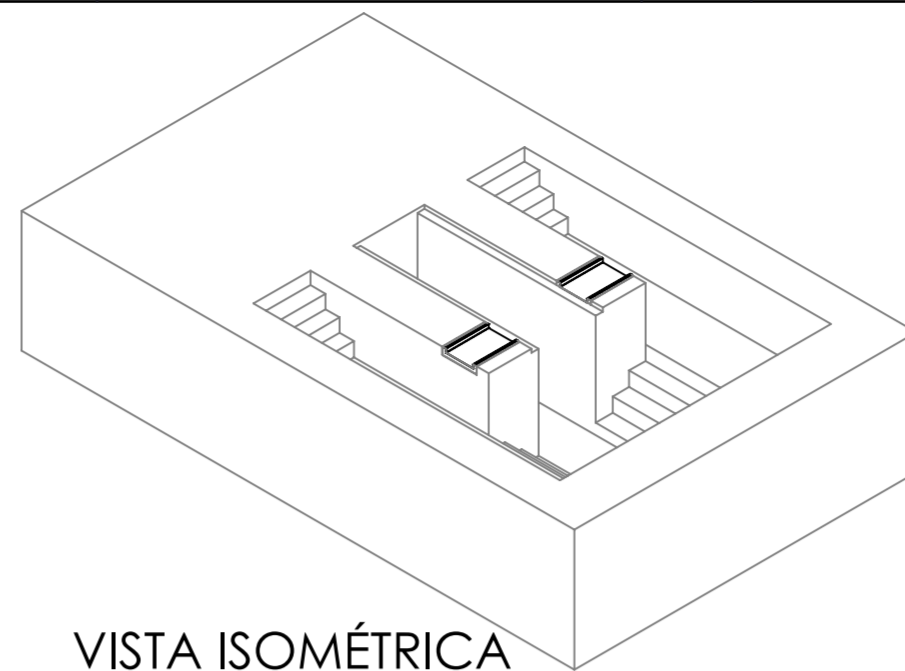

VISTA ISOMÉTRICA
ESC.: 1:75

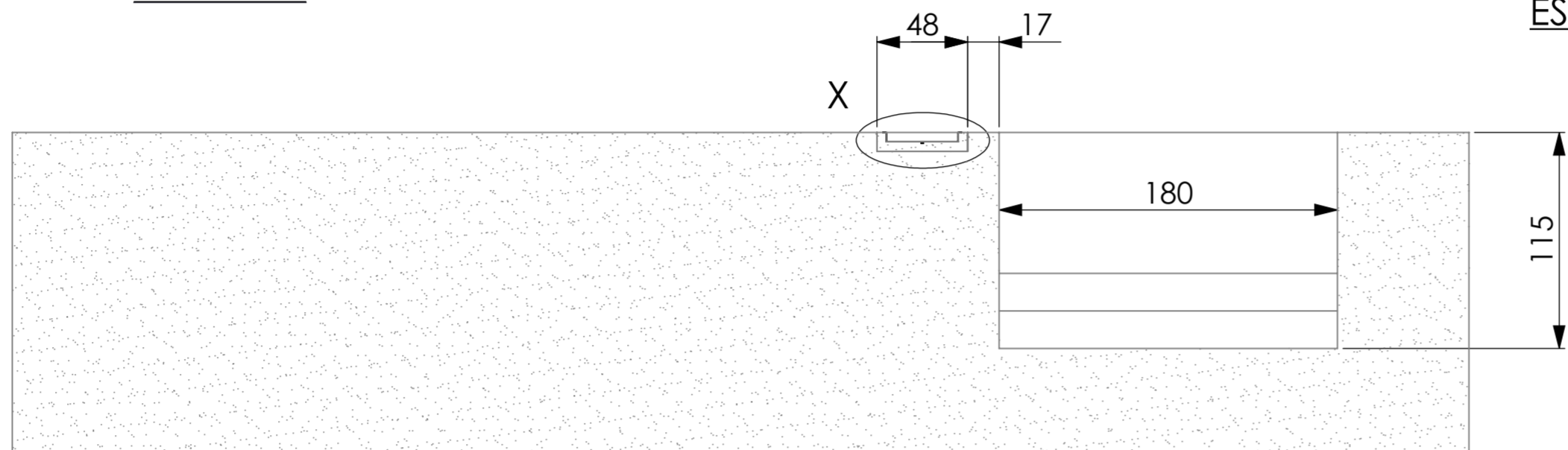

CORTE A-A

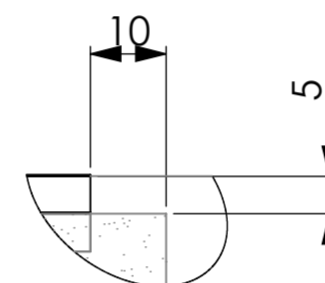

EXIBIR Y
ESCALA 1:10

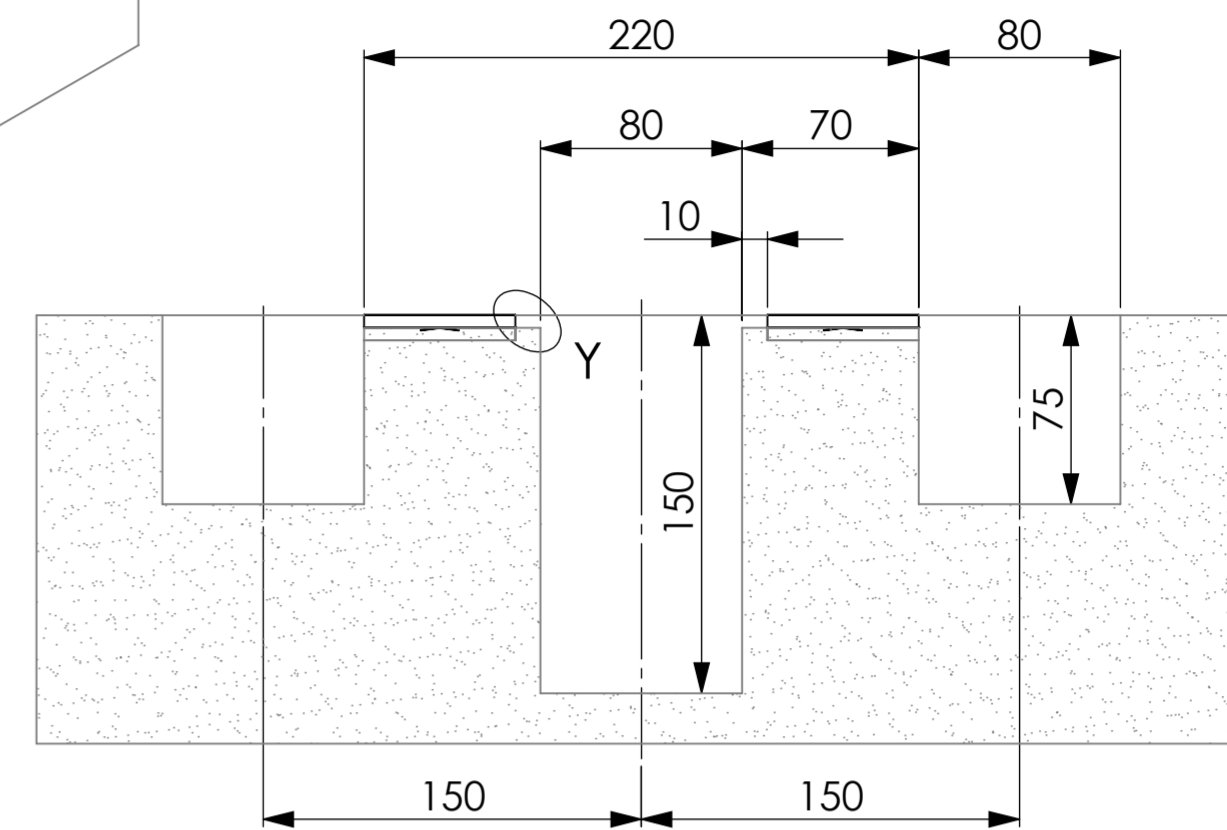

CORTE B-B

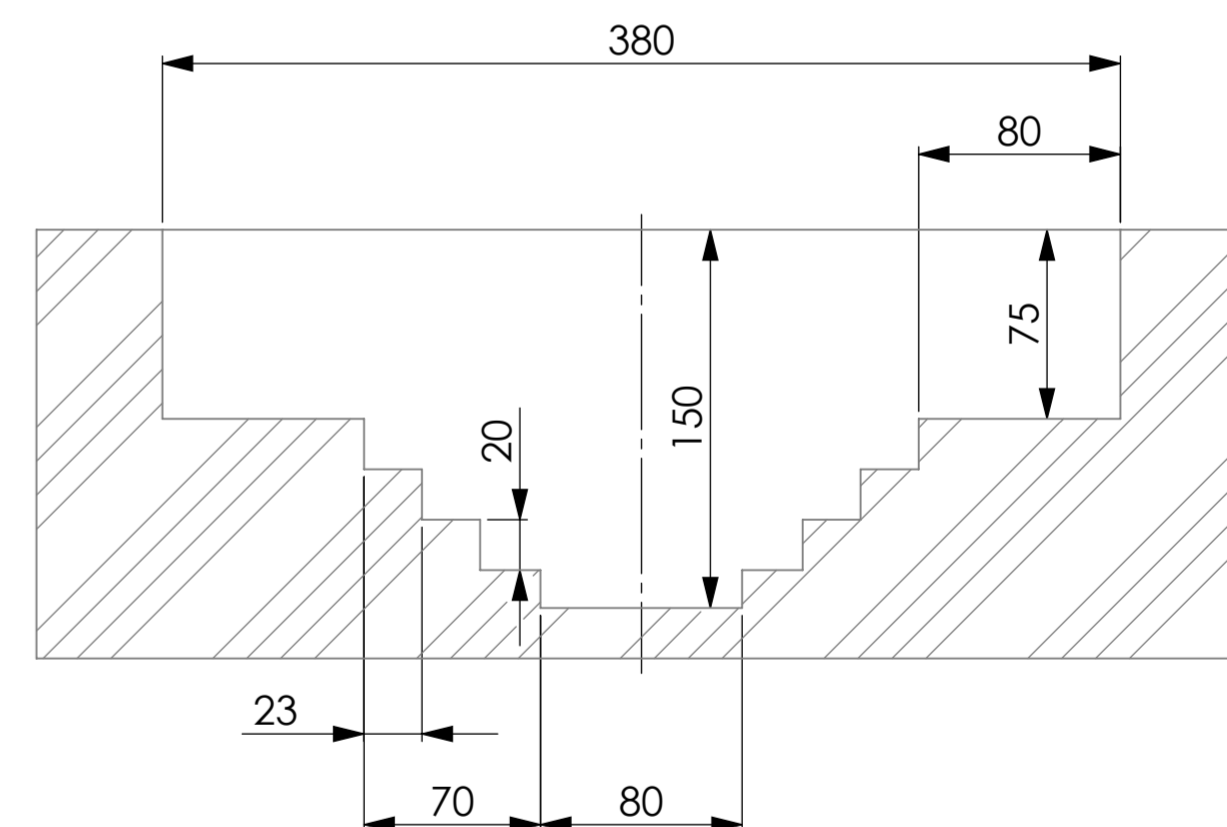

CORTE C-C

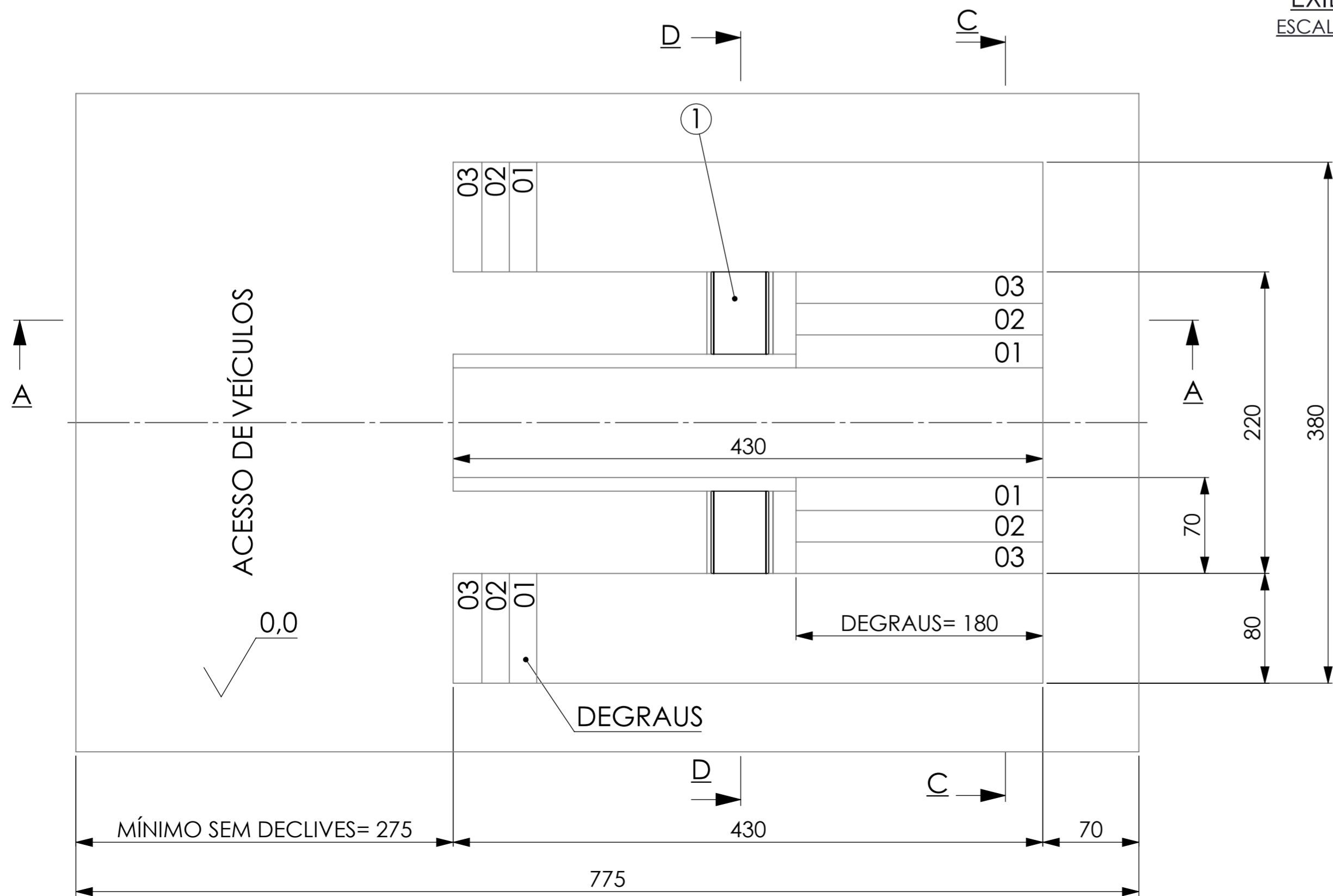

Nº DO ITEM	Nº DA PEÇA	DESCRIÇÃO	QTD.	MASSA
1	1345	BANDEJA DIANTEIRA PARA VALA	2	3.76
MFG MÁQUINAS		PROJEÇÃO	Massa:	
desenvolvimento@mfgmaquinas.com.br (47) 3564-0336		1º DIEDRO	Programa de Dobra:	
Desenho/Nome	Data	Projeto:	Nº Modelo:	
DIEGO BURATO	20/09/2018	VALA DE ALINHAMENTO	ID de produto:	
Unidade de Medida			Nº Desenho:	
mm			1650	
Acabamento Geral	Escala:	Título:	Rev.:	
∇	1:30	LAYOUT CIVIL - VALA CURTA		